

# Diaphragm Design

Roofing elements have been designed to perform as structural diaphragms for many years in earthquake-prone regions including, Zones 3 & 4 (see *Figure 1*). The use of the principles of diaphragm design is more recently gaining widespread acceptance in areas subject to high wind load (see *Figure 2*). These hurricane, tornado, and windstorm-prone areas of the United States are using roof diaphragm design as a cost effective and sound engineering alternative to diagonal bracing, drag struts, and other methods of accommodating such forces.

The roof diaphragm is an assembly of joists and panels. The panels are attached to the joists and cause the roof construction to act like the web of an I-beam when subjected to lateral forces. The roof diaphragm braces the walls and allows lateral load transfers from the roof level through walls to the foundation.

Several important factors affect the design and performance of diaphragm constructions. Principally, they are the steel deck gauge and section properties related to load/span tables, the method of attaching the steel deck to the joist system, and the diaphragm to wall connection.

## ***Design Procedures/Load-Span Tables***

The specific design procedure for diaphragm construction varies by geographical location in the United States. For example, the California area procedures for earthquake design are governed by the Uniform Building Code Chapter 23 design procedure. Generally, systems approved by the Uniform Building Code have their design parameters determined by actual system testing. The diaphragm design shear forces and deflection criteria are developed from these tests. Tables 1 and 2 show the design values as determined from results of testing several Siplast Lightweight Insulating Concrete Systems using this approach.

In the eastern United States, the design of diaphragm roof systems follows the procedures outlined by the Steel Deck Institute (SDI) Diaphragm Design Manual. The SDI procedures use equations supported by test data based on work conducted by Dr. Larry Luttrell at West Virginia University. Tables 4 through 15 provide tabular shear design data for the Siplast Insulcel and Zonocel Lightweight Insulating Concrete Systems with various steel deck profiles, weld patterns, and spans. The tabular design shear values are for the field of the diaphragm. The formulas given in this section are used to calculate the design shear for three common types of boundary conditions.

To properly use any of these tables, please consult your local building authority's design procedures to determine what approach is acceptable.

### ***Methods of Steel Deck Attachment***

Historically, welding has been the predominant method of attachment. When welding, a (24-gauge or thinner metal decking) weld washers of minimum 16-gauge thickness with a  $\frac{3}{8}$ -inch diameter hole should be used. When welding 22-gauge or thicker metal, weld washers are not required. Inspection of the welds and welding procedure should be in accordance with the Structural Welding Code for Sheet Steel, ANSI/AWS D 1.3, published by the American Welding Society.

Many current applications of diaphragms are completed by insertion of metal pins to hold the steel decking to the joist system. Shear capacity tables for this method of attachment are published by either the fastener suppliers or by steel deck manufacturers. Consult with either of these sources for further information.

Stitch screws, button punching, or welding of the side laps of steel decks will achieve higher shear load values. Where this procedure is required, it is shown with the appropriate design value. A minimum #12 diameter screw is required where stitch screws are shown.

The location of welds and frequency of welding the steel deck to supports is shown in Table 3. Please note that two methods are used to specify welding patterns for the more commonly used steel decking profiles. Side lap welding at the edge of a wall should occur at no less than the spacing of the end support weld frequency for the steel deck.

Some manufacturers of steel decking have designed shear transfer elements for use on the ends of steel decking at shear collection locations. The shear transfer elements increase the diaphragm values when properly designed and installed. The values in Table 2 all show diaphragm values for a Siplast ZIC mix using a shear transfer element. Consult the specific steel deck manufacturer's catalog for details.

### ***Diaphragm to Wall Connection***

For a diaphragm to function by transferring load to a wall, it must be adequately connected to the wall. The wall connection must be designed to resist the shear and tension loads at the wall. The steel deck must be able to be welded to the wall shear transfer member. Figures 3 and 4 show two typical approaches to wall connections that allow for proper welding procedures.

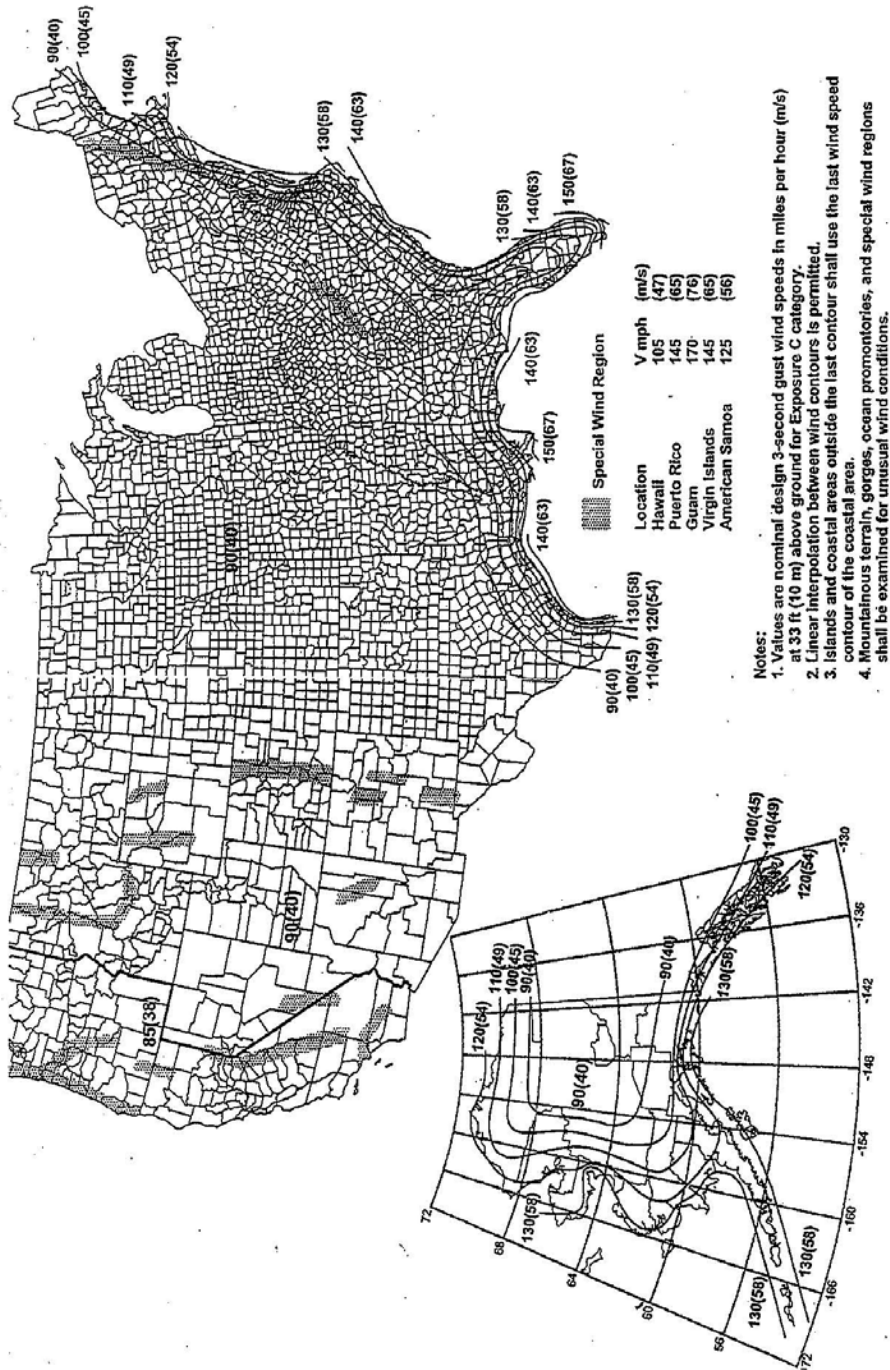
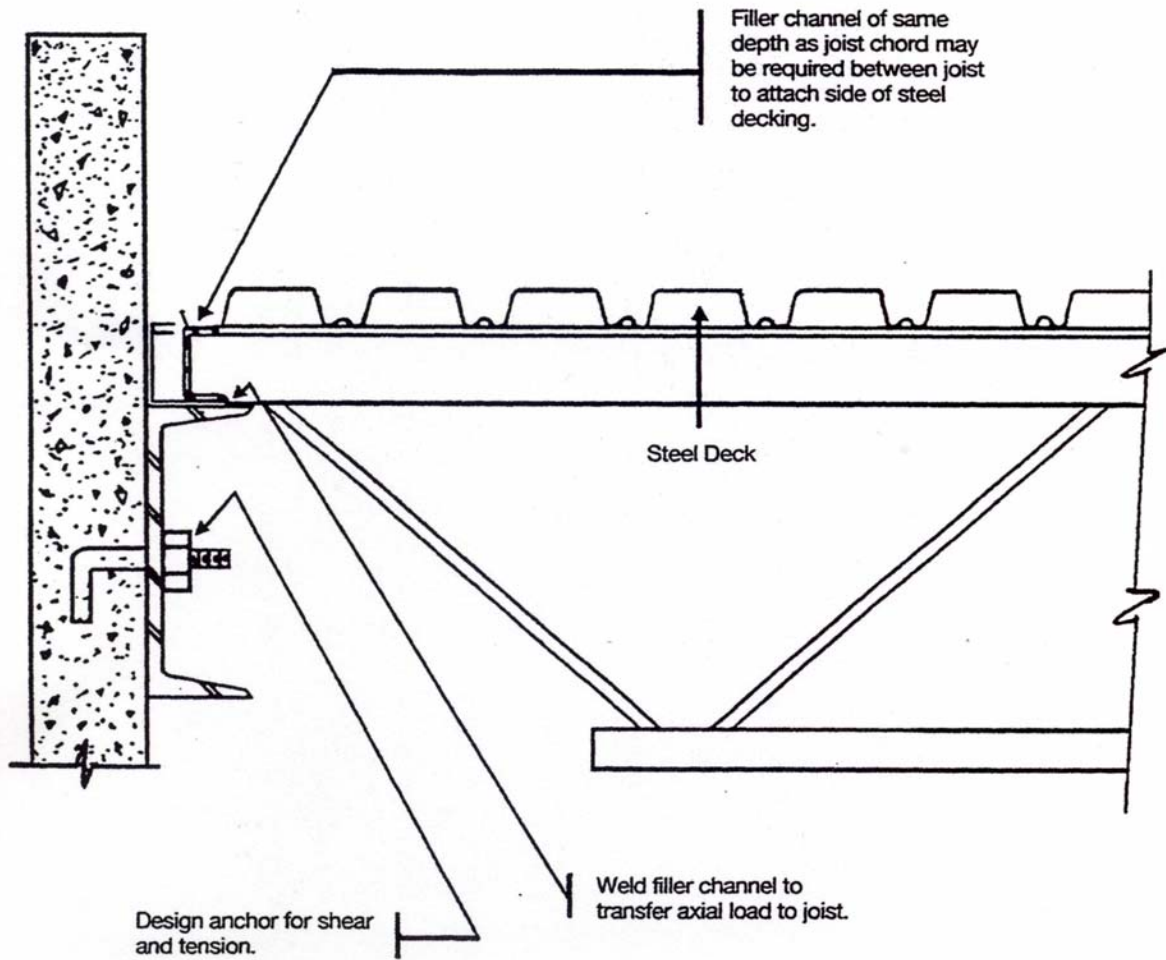

FIGURE 1609—continued  
BASIC WIND SPEED (3-SECOND GUST)

FIGURE 1609  
BASIC WIND SPEED (3-SECOND GUST)

**Figure 3**  
**Typical Side Panel Connection for Shear Transfer**



Note: Filler channel is often installed "legs down" for more stability during welding.

**Figure 4**  
**Typical End Panel Connection for Shear Transfer**

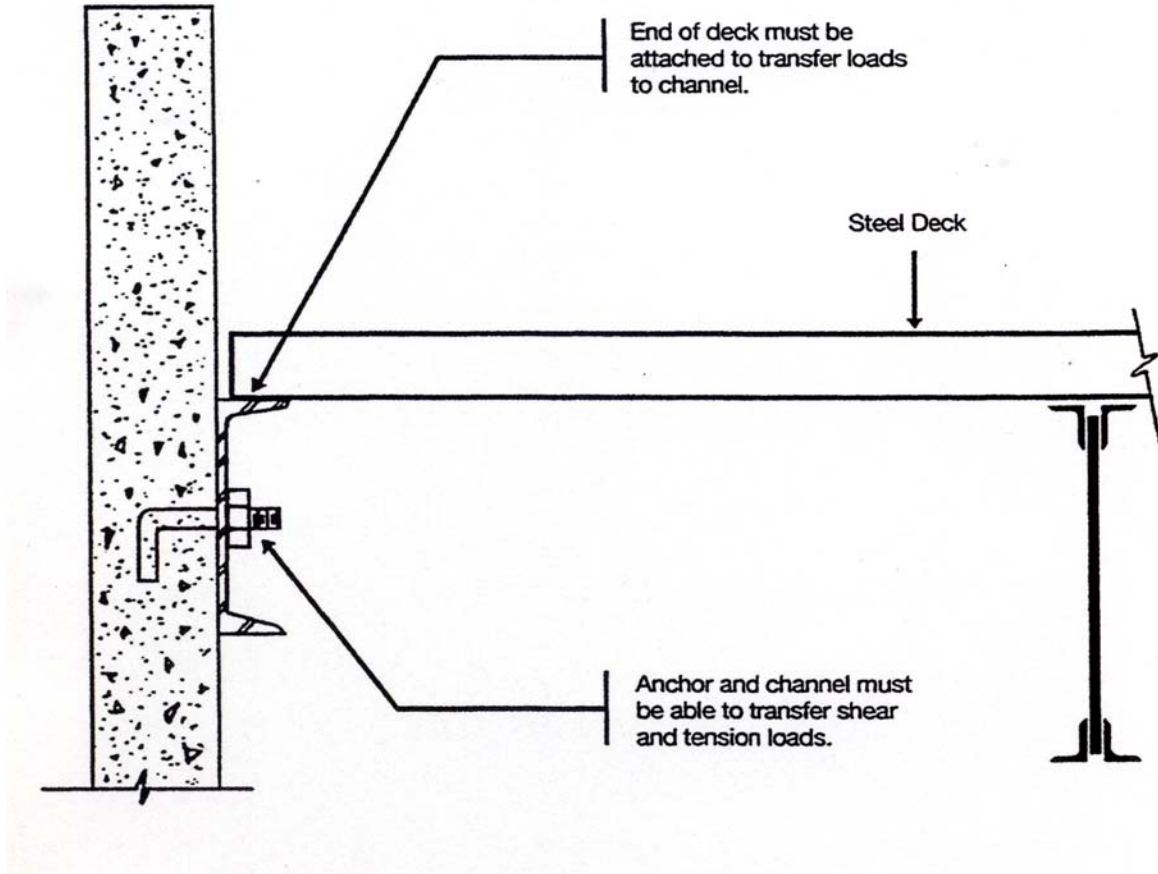

**Table 1**  
**Allowable Diaphragm Values and Flexibility Factors for**  
**ZIC/Insulperm Roof Decks on High Strength Steel Deck**

Gauge	Metal Thickness	Depth of Deck Corrugation	Weld Pattern	Max. Span (Feet)	Working Shear q (lb/ft)	Flexibility Factor F	Working Shear q (lb/ft)	Flexibility Factor F
16	.0598 t	1 5/16"	3-3	8'	1,130	4.5	--	--
18	.0478 t .0498	1 5/16"	3-3	8'	960	4.5	--	--
20	.0359 t .0478	1 5/16"	3-3	8'	790	4.5	--	--
22	.0299 t .0359	1 5/16"	3-3	8'	730	4.5	--	--
24	.0239 t .0299	1 5/16"	3-3	8'	660	4.5	570	4.5
		1 5/16"	2-2	8'	410	13.5	410	4.5
		7/8"	2-2	4'	410	13.5	--	--
26	.0179 t .0239	1 5/16"	3-3	8'	570	4.5	570	9.0
		1 5/16"	2-2	8'	250	13.5	250	9.0
		7/8"	3-3	4'	820	4.5	--	--
		7/8"	3-3	6'	460	4.5	--	--
		7/8"	2-2	4'	340	18.0	--	--
		7/8"	2-2	5'	330	22.5	--	--
28	.0149 t .0179	9/16"	2-2	4'	320	4.5		

1. Maximum span conditions are for diaphragm values only. In no case should the span exceed the downward load carrying capabilities of the sheet.
2. Metal thicknesses are nominal base metal thicknesses.
3. The slotted metal deck shall be a nominal 1.5% open area with non-continuous slots in either the web or bottom of the corrugation.
4. Working shear values in Table 1 allow Insulperm to be incorporated in thicknesses ranging from 3/4" to 4". Working shear values for Insulperm thickness from 4 1/4" to 8" must be multiplied by 0.85 to reduce the value.
5. No mesh is required in the insulating concrete.
6. Flexibility factor or is the design deflection of the diaphragm when loaded to one pound of shear. The value is  $F \times 10^{-6}$  inches/foot of span.
7. Welding technique should follow AWS D1.3 specifications.
8. Weld patterns are identified by two numbers; the first referring to end support framing locations, and the second to interior support framing locations.
9. A 3-3 welding pattern uses welding washers in every corrugation over each support.
10. A 2-2 welding pattern uses welding washers at each side lap and at two intermediate corrugations at each support.
11. Perimeter welding of the diaphragm shall have a maximum spacing of 12" o.c. No side lap attachment between adjacent sheets of the metal is required.
12. Working shear safety factor = 3.

**Table 2**  
**Steel Deck Manufacturers Diaphragm Values**  
**for ZIC (1:6 Mix)**

ASC Pacific, Inc. – Refer to ICBO Report No. 2757

Allowable Diaphragm Shears for 'Shear-vent' System using ASC B-30 Decks

Gauge	SPAN				
	6' - 0"	7' - 0"	8' - 0"	9' - 0"	10' - 0"
22	1090 / 1520	1010 / 1410	940 / 1320	890 / 1250	840 / 1180
20	1250 / 1690	1160 / 1620	1080 / 1510	1020 / 1430	970 / 1350
18	1550 / 1690	1430 / 1690	1340 / 1690	1270 / 1690	1200 / 1680

1. Values above the diagonal line are for seams fastened with button-punches.
2. Those below are fastened with top seam welds.
3. All seam fasteners are 24 inches on center maximum.

Verco Manufacturing Co. – Refer to ICBO Report No. 2078

Allowable Diaphragm Shears for Verco Decks B-30 & B-36 Constructed using System 80

Gauge	SPAN				
	6' - 0"	7' - 0"	8' - 0"	9' - 0"	10' - 0"
22	/	/	880 / 1160	/	/
20	/	/	970 / 1430	890 / 1340	820 / 1260
18	/	/	1030 / 1520	990 / 1490	960 / 1480

1. Values above the diagonal line are for seams fastened with button-punched 24" o.c.
2. Values below the diagonal line are the seams welded at 16" o.c.

Elixir Industries – Refer to ICBO Report No. 4176

Allowable Diaphragm Shears for Elixir Industries 'B' Deck using the 'Atlas' System

Gauge	SPAN				
	6' - 0"	7' - 0"	8' - 0"	9' - 0"	10' - 0"
22	960 / 1880	870 / 1750	800 / 1660	750 / 1600	720 / 1540
20	1130 / 2070	1020 / 1940	940 / 1840	890 / 1770	840 / 1720
18	1400 / 2400	1340 / 2270	1230 / 2170	1160 / 2100	1100 / 2040

1. Values above the diagonal line are for seams fastened with button-punched 24" o.c.
2. Values below the diagonal line are the seams welded at 12" o.c.

**Table 3**  
**Weld Pattern Designations**

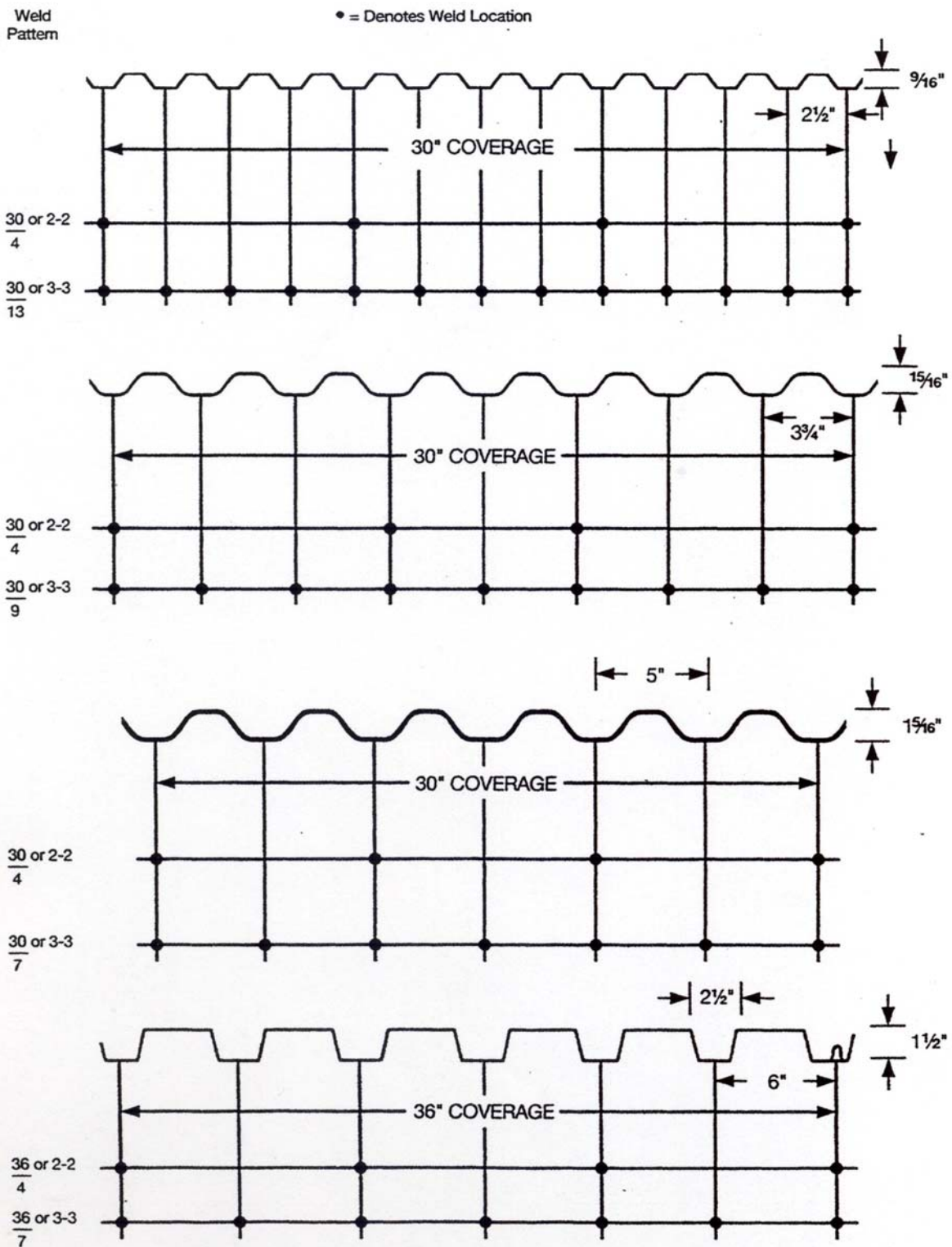



## Guide to Using the Insulcel and Zonocel Lightweight Insulating Concrete Diaphragm Tables

The design shear values presented in the following tables are for the field of the diaphragm. In order to effectively transfer shear forces from the upper slab into the structural supports, hi-chair connections may be used at the perimeter of the diaphragm.

Two types of hi-chair connections have been evaluated (see Figure 5).

Three boundary conditions have been developed for design purposes. They are:

- Type I** Insulperm held back 1 inch from edge
- Type II** Insulperm held back 12 inches from edge
- Type III** Insulperm held back 12 inches from edge and hi-chair connectors used. Chair spacing along the diaphragm edge parallel to deck span ( $L_v$ ) is calculated using equation for Type III boundary condition below. Chairs are also placed on the perimeter supporting deck ends at spacings no greater than the deck panel width.

The equations for adapting the tabular shear values to these three boundary conditions are:

$$\text{Type I} \quad S_1 = S_{tb} - (1-k_1) (64\sqrt{f_c}) / 3.25$$

$$\text{Type II} \quad S_2 = S_{tb} - (1-k_2) (64\sqrt{f_c}) / 3.25$$

$$\text{Type III} \quad S_3 = S_2 + [12 Q_{uc}/e_h] / 3.25$$

where:

- S = design shear, lbs. per ft.
- $S_{tb}$  = design shear from the tables
- $Q_{uc}$  = hi-chair shear strength, lbs.
- $k_1$  =  $0.73/pd$
- $k_2$  =  $1.30/pd$
- p = deck rib spacing, in.
- d = steel deck depth, in.
- $e_h$  = perimeter spacing of chairs, in.\*
- $f_c$  = concrete compressive strength, psi

*\*Chair spacing should not exceed deck support spacing along diaphragm panel longitudinal edge. Chair spacing should not exceed panel width across the diaphragm panel ends.*

### Common Design Cases

The following table summarize pertinent data for five common metal deck configurations:

Deck Type	d (in)	p (in)	k <sub>1</sub>	k <sub>2</sub>
1 (28 ga)	9/16	2 ½	0.519	0.924
2 (26 ga)	15/16	3 ¼	0.208	0.370
3 (24, 22, 20 ga)	1 5/16	5	0.111	0.198
4 (24, 22, 20 ga)	1 ½	6	0.081	0.144
5 (24, 22, 20 ga)	2	6	0.061	0.108

Boundary Condition	Deck Type	Allowable Design Shears (lb/ft)	
		200 psi concrete	300 psi concrete
I	General	$S_1 = S_{tb} - 278 (1-k_1)$	$S_1 = S_{tb} - 341 (1-k_1)$
I	1	$S_1 = S_{tb} - 134$	$S_1 = S_{tb} - 164$
I	2	$S_1 = S_{tb} - 221$	$S_1 = S_{tb} - 270$
I	3	$S_1 = S_{tb} - 248$	$S_1 = S_{tb} - 303$
I	4	$S_1 = S_{tb} - 256$	$S_1 = S_{tb} - 313$
I	5	$S_1 = S_{tb} - 262$	$S_1 = S_{tb} - 320$
II	General	$S_2 = S_{tb} - 278 (1-k_2)$	$S_2 = S_{tb} - 341 (1-k_2)$
II	1	$S_2 = S_{tb} - 21$	$S_2 = S_{tb} - 26$
II	2	$S_2 = S_{tb} - 176$	$S_2 = S_{tb} - 215$
II	3	$S_2 = S_{tb} - 223$	$S_2 = S_{tb} - 273$
II	4	$S_2 = S_{tb} - 238$	$S_2 = S_{tb} - 292$
II	5	$S_2 = S_{tb} - 248$	$S_2 = S_{tb} - 304$
III	General	$S_3 = S_2 + 12 (Q_{uc}/e_h) / 3.25$	$S_3 = S_2 + 12 (Q_{uc}/e_h) / 3.25$
III	A chair	$S_3 = S_2 + 2526/e_h$	$S_3 = S_2 + 4194/e_h$
III	B chair	$S_3 = S_2 + 2393/e_h$	$S_3 = S_2 + 2917/e_h$

### Example Calculation

A  $\frac{15}{16}$ -inch deep steel panel diaphragm with Insulcel Lightweight Insulating Concrete is to be used for a design to resist design shears of  $S = 450$  lb per ft. The deck span  $L_v = 5$  ft. From the load tables:

- $d = \frac{15}{16}$  in. (Type 2 deck)
- $f_c = 200$  psi
- Normal welding pattern
- One stitch screw per span on sidelaps
- $S_{tb} = 461$  lb per ft,  $S = 450$  lb per ft O.K. for field of diaphragm
- $t = 0.0179$ " sheet thickness (26 ga)

From the shear formulas listed above:

#### **For Boundary Type II:**

$$S_2 = S_{tb} - 176 = 461 - 176 = 285 \text{ lb/ft.}$$

With no hi-chair connections at the edge, the available working shear is well below the 450 lb/ft that is required.

#### **For Boundary Type III using A-chairs:**

$$S_3 = S_2 + 2526/e_h = 285 + 2526/e_h$$

$S_3$  is required to be no larger than the **required** capacity, 450 lb/ft. Therefore,  $S_3 = 450$  lb/in.

$$450 = 285 + 2526/e_h \text{ or } 165 = 2526/e_h$$

Solving for  $e_h$  :  $e_h = 2526/165 = 15.3$  inches

The chairs should be spaced at about a 15-inch maximum along the diaphragm edge parallel to the deck span  $L_v$ . The same type hi-chairs should be placed on the perimeter, supporting deck ends, at spacings no greater than 15.3 inches. For a  $\frac{15}{16}$ -inch deck with a  $3\frac{3}{4}$ -inch pitch, this would be every fourth corrugation or 15 inches on center.

**Figure 5**  
**High-Chair Connectors**

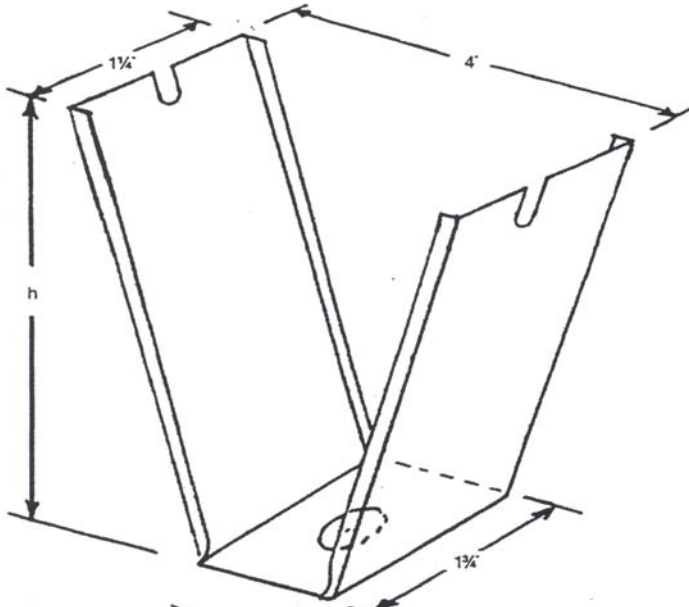

**Chair A**

- Hole  $\frac{3}{8}$ "
- Lip rolled out for  $1\frac{1}{4}$ " wide base
- Groove at top  $\frac{7}{16}$ " wide x  $\frac{3}{16}$ " deep
- $h = 4"$  or cut to  $3\frac{1}{2}"$
- Thickness  $0.0315\pm$

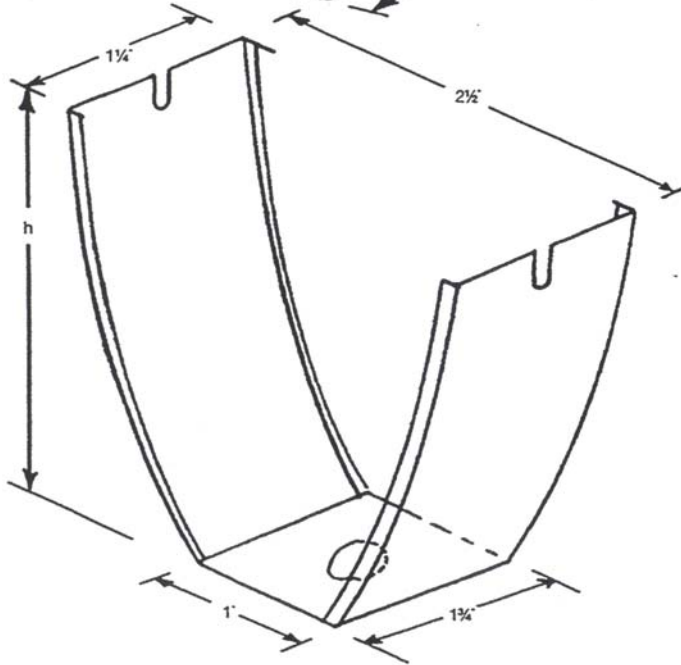

**Chair B**

- $\frac{3}{8}$ " Hole
- Rolled out base  $1\frac{1}{4}$ " wide
- Top groove as above
- Leg lip =  $\frac{1}{4}$ "
- Thickness  $0.036\pm$
- $h = 3\frac{1}{2}"$

**Table 4**  
**Insulcel and Zonocel Diaphragm Values — Field of Diaphragm**  
**Minimum 200 psi Concrete — 28-gauge Metal Decking —  $\frac{3}{16}$ -Inch Profile Depth**

Welding Pattern	Number Stitch Connectors	Spans (feet)									
		3.0		3.5		4.0		4.5		5.0	
		Design Shear lb/ft	Design Shear Stiffness kips/in	Design Shear lb/ft	Design Shear Stiffness kips/in	Design Shear lb/ft	Design Shear Stiffness kips/in	Design Shear lb/ft	Design Shear Stiffness kips/in	Design Shear lb/ft	Design Shear Stiffness kips/in
30/4 End and Interior Supports	0	461	335.7	435	330.9	415	326.9	400	323.6	388	320.8
	1	494	347.5	463	342.3	440	337.9	422	334.2	408	330.9
	2	526	356.5	491	351.2	464	346.7	444	342.7	427	339.2
	3	559	363.6	519	358.3	489	353.8	466	349.7	447	346.2
	4	592	369.3	547	364.2	514	359.7	487	355.6	467	352.0
30/13 Panel Ends  30/4 Interior Supports	0	577	355.6	534	350.3	502	345.8	477	341.9	457	338.4
	1	610	362.9	562	357.6	527	353.1	499	349.0	477	345.4
	2	642	368.7	590	363.6	551	359.1	521	355.0	497	351.4
	3	675	373.5	619	368.6	576	364.1	543	360.1	517	356.5
	4	708	377.5	647	372.8	601	368.4	565	364.5	536	361.0
30/13 All Supports	0	693	368.1	634	363.0	589	358.5	555	354.4	527	350.8
	1	726	373.0	662	368.1	614	363.6	577	359.6	547	356.0
	2	759	377.1	690	372.3	639	368.0	599	364.1	567	360.5
	3	791	380.6	718	376.0	663	371.8	620	367.9	586	364.4
	4	824	383.6	746	379.1	688	375.1	642	371.3	606	367.9

**Notes:**

- Maximum span conditions are for diaphragm values only. In no case should the span exceed downward load carrying capabilities of the sheet.
- Insulperm is optional with these values. Insulperm when used is limited to 4-inch maximum thickness.
- Edge of diaphragm connections should not exceed the spacing, determined by the following formula:  

$$\text{Spacing (inches)} = 3690 Q_f/s$$

Where:  $Q_f$  = is weld strength (kips) from SDI Diaphragm Design Manual Section 4  
 $S$  = Design Shear (PLF)
- Design Shear Safety Factor = 3.25
- Boundary condition design should be calculated as indicated on the page titled Guide To Using The Insulcel and Zonocel Diaphragm Tables.

**Table 5**  
**Insulcel and Zonocel Concrete Diaphragm Values — Field of Diaphragm —**  
**Minimum 200 psi Concrete — 26-gauge Metal Decking —  $\frac{15}{16}$ -Inch Profile Depth**

Welding Pattern	Number Stitch Connectors	Spans (feet)									
		4.0		4.5		5.0		5.5		6.0	
		Design Shear lb/ft	Design Shear Stiffness kips/in	Design Shear lb/ft	Design Shear Stiffness kips/in	Design Shear lb/ft	Design Shear Stiffness kips/in	Design Shear lb/ft	Design Shear Stiffness kips/in	Design Shear lb/ft	Design Shear Stiffness kips/in
30/4 End and Interior Supports	0	477	340.2	455	335.5	438	331.6	423	328.2	411	325.3
	1	507	354.6	482	349.1	461	344.5	445	340.5	431	337.0
	2	537	366.6	508	360.7	485	355.6	466	351.1	451	347.2
	3	566	376.9	534	370.7	509	365.3	488	360.5	470	356.3
	4	596	385.7	561	379.4	532	373.8	509	368.8	490	364.4
30/13 Panel Ends  30/4 Interior Supports	0	527	352.8	500	347.5	477	342.9	459	339.0	444	335.5
	1	557	365.2	526	359.3	501	354.2	481	349.8	464	345.9
	2	586	375.6	552	369.5	525	364.1	502	359.3	484	355.1
	3	616	384.6	579	378.3	549	372.7	524	367.8	504	363.3
	4	646	392.5	605	386.0	572	380.3	546	375.3	523	370.7
30/13 All Supports	0	577	363.6	544	357.8	517	352.8	496	348.5	477	344.6
	1	607	374.3	570	368.2	541	362.8	517	358.2	497	354.0
	2	636	383.5	596	377.2	565	371.6	539	366.7	517	363.3
	3	666	391.5	623	385.1	588	379.4	560	374.3	537	369.8
	4	695	398.5	649	392.0	612	386.3	582	381.1	556	376.5

**Notes:**

- Maximum span conditions are for diaphragm values only. In no case should the span exceed downward load carrying capabilities of the sheet.
- Insulperm is optional with these values. Insulperm when used is limited to 4-inch maximum thickness.
- Edge of diaphragm connections should not exceed the spacing, determined by the following formula:  

$$\text{Spacing (inches)} = 3690 \frac{Q_f}{S}$$
 Where:  $Q_f$  = is weld strength (kips) from SDI Diaphragm Design Manual Section 4  
 $S$  = Design Shear (PLF)
- Design Shear Safety Factor = 3.25
- Boundary condition design should be calculated as indicated on the page titled Guide To Using The Insulcel and Zonocel Diaphragm Tables.

**Table 6**  
**Insulcel and Zonocel Concrete Diaphragm Values — Field of Diaphragm —**  
**Minimum 200 psi Concrete — 26-gauge Metal Decking — 1<sup>5/16</sup>-Inch Profile Depth**

Welding Pattern	Number Stitch Connectors	Spans (feet)									
		4		4.5		5		5.5		6	
		Design Shear lb/ft	Design Shear Stiffness kips/in	Design Shear lb/ft	Design Shear Stiffness kips/in	Design Shear lb/ft	Design Shear Stiffness kips/in	Design Shear lb/ft	Design Shear Stiffness kips/in	Design Shear lb/ft	Design Shear Stiffness kips/in
30/4 End and Interior Supports	0	455	328.7	436	325.1	420	322.0	407	319.4	396	317.1
	1	485	341.1	462	336.9	444	333.2	429	330.0	416	327.3
	2	515	351.3	488	346.7	467	342.7	450	339.1	436	336.0
	3	544	359.7	515	354.9	491	350.7	472	347.0	456	343.6
	4	574	366.9	541	362.0	515	357.7	493	353.8	475	350.3
30/7 Panel Ends 30/4 Interior Supports	0	491	336.2	467	332.2	448	328.7	433	325.8	420	323.2
	1	520	347.3	493	342.8	472	338.9	454	335.5	440	332.5
	2	550	356.4	520	351.6	496	347.5	476	343.8	459	340.6
	3	580	364.0	546	359.1	519	354.9	497	351.0	479	347.6
	4	609	370.5	572	365.6	543	361.3	519	357.3	499	353.8
30/7 All Supports	0	526	342.9	499	338.5	477	334.8	459	331.6	444	328.7
	1	556	352.7	525	348.1	500	344.0	480	340.5	463	337.3
	2	585	360.9	551	356.1	524	351.9	502	348.1	483	344.8
	3	615	367.9	578	363.0	548	358.7	523	354.8	503	351.3
	4	645	373.9	604	369.0	571	364.6	545	360.7	523	357.1

**Notes:**

- Maximum span conditions are for diaphragm values only. In no case should the span exceed downward load carrying capabilities of the sheet.
- Insulperm is optional with these values. Insulperm when used is limited to 4-inch maximum thickness.
- Edge of diaphragm connections should not exceed the spacing, determined by the following formula:  

$$\text{Spacing (inches)} = 3690 Q_f / S$$
 Where:  $Q_f$  = is weld strength (kips) from SDI Diaphragm Design Manual Section 4  
 $S$  = Design Shear (PLF)
- Design Shear Safety Factor = 3.25
- Boundary condition design should be calculated as indicated on the page titled Guide To Using The Insulcel and Zonocel Diaphragm Tables.

**Table 7**  
**Insulcel and Zonocel Concrete Diaphragm Values — Field of Diaphragm —**  
**Minimum 200 psi Concrete — 24-gauge Metal Decking — 1<sup>5</sup>/<sub>16</sub>-Inch Profile Depth**

Welding Pattern	Number Stitch Connectors	Spans (feet)									
		4.5		5.0		5.5		6.0		6.5	
		Design Shear lb/ft	Design Shear Stiffness kips/in	Design Shear lb/ft	Design Shear Stiffness kips/in	Design Shear lb/ft	Design Shear Stiffness kips/in	Design Shear lb/ft	Design Shear Stiffness kips/in	Design Shear lb/ft	Design Shear Stiffness kips/in
30/4 End and Interior Supports	0	519	332.9	495	329.1	475	325.9	459	323.1	445	320.7
	1	554	347.6	526	343.0	504	339.0	485	335.6	469	332.5
	2	589	360.0	558	354.8	533	350.4	511	346.5	493	343.0
	3	624	370.6	590	365.1	561	360.3	538	356.1	518	352.3
	4	659	379.8	621	374.1	590	369.1	564	364.6	542	360.5
30/13 Panel Ends  30/4 Interior Supports	0	567	341.8	538	337.5	514	333.8	495	330.6	478	327.8
	1	602	355.0	570	350.1	543	345.8	521	342.1	502	338.8
	2	637	366.3	601	361.0	572	356.3	547	352.2	527	348.5
	3	672	376.1	633	370.5	601	365.5	574	361.1	551	357.2
	4	707	384.6	664	378.8	629	373.7	600	369.1	575	365.0
30/13 All Supports	0	615	349.8	581	345.1	554	341.0	531	337.5	511	334.4
	1	650	361.8	613	356.6	582	352.1	557	348.1	536	344.6
	2	685	372.2	644	366.7	611	361.8	583	357.5	560	353.7
	3	720	381.2	676	375.5	640	370.4	610	365.9	584	361.8
	4	755	389.0	708	383.2	669	378.0	636	373.4	609	369.2

**Notes:**

1. Maximum span conditions are for diaphragm values only. In no case should the span exceed downward load carrying capabilities of the sheet.
2. Insulperm is optional with these values. Insulperm when used is limited to 4-inch maximum thickness.
3. Edge of diaphragm connections should not exceed the spacing, determined by the following formula:

$$\text{Spacing (inches)} = 3690 Q_f / S$$

Where:  $Q_f$  = is weld strength (kips) from SDI Diaphragm Design Manual Section 4

$S$  = Design Shear (PLF)

4. Design Shear Safety Factor = 3.25
5. Boundary condition design should be calculated as indicated on the page titled Guide To Using The Insulcel and Zonocel Diaphragm Tables.



**Table 8**  
**Insulcel and Zonocel Concrete Diaphragm Values — Field of Diaphragm —**  
**Minimum 200 psi Concrete — 22-gauge Metal Decking — 1<sup>5</sup>/<sub>16</sub>-Inch Profile Depth**  
**and 1 1/2" B-Deck**

Welding Pattern	Number Stitch Connectors	Spans (feet)									
		5.0		5.5		6.0		6.5		7.0	
		Design Shear lb/ft	Design Shear Stiffness kips/in	Design Shear lb/ft	Design Shear Stiffness kips/in	Design Shear lb/ft	Design Shear Stiffness kips/in	Design Shear lb/ft	Design Shear Stiffness kips/in	Design Shear lb/ft	Design Shear Stiffness kips/in
30/4 End and Interior Supports	0	583	334.8	555	331.0	532	327.8	513	325.1	496	322.6
	1	622	351.2	591	346.5	565	342.5	543	338.9	524	335.8
	2	662	365.4	627	360.0	598	355.4	574	351.3	552	347.7
	3	702	377.8	663	372.0	631	366.9	604	362.4	581	358.3
	4	741	388.7	699	382.6	664	377.2	634	372.3	609	368.0
30/13 Panel Ends 30/4 Interior Supports	0	644	344.5	611	340.2	583	336.5	559	333.2	539	330.4
	1	683	359.5	647	354.5	616	350.1	590	346.2	568	342.8
	2	723	372.7	683	367.1	649	362.2	620	357.8	596	353.9
	3	763	384.2	719	378.2	682	372.9	651	368.2	624	364.0
	4	802	394.4	754	388.2	715	382.6	681	377.6	652	373.1
30/13 All Supports	0	705	353.4	666	348.6	634	344.5	606	340.9	583	337.7
	1	744	367.3	702	361.9	667	357.2	637	353.0	611	349.3
	2	784	379.5	738	373.6	700	368.5	667	363.9	639	359.8
	3	823	390.2	774	384.1	733	378.6	698	373.7	668	369.3
	4	863	399.8	810	393.5	766	387.8	728	382.6	696	378.0

**Notes:**

1. Maximum span conditions are for diaphragm values only. In no case should the span exceed downward load carrying capabilities of the sheet.
2. Insulperm is optional with these values. Insulperm when used is limited to 4-inch maximum thickness.
3. Edge of diaphragm connections should not exceed the spacing, determined by the following formula:

$$\text{Spacing (inches)} = 3690 Q_f/s$$

Where:  $Q_f$  = is weld strength (kips) from SDI Diaphragm Design Manual Section 4

$S$  = Design Shear (PLF)

4. Design Shear Safety Factor = 3.25
5. Boundary condition design should be calculated as indicated on the page titled Guide To Using The Insulcel and Zonocel Diaphragm Tables.

**Table 9**  
**Insulcel and Zonocel Concrete Diaphragm Values — Field of Diaphragm —**  
**Minimum 200 psi Concrete — 20-gauge Metal Decking — 1<sup>5</sup>/<sub>16</sub>-Inch Profile Depth**

Welding Pattern	Number Stitch Connectors	Spans (feet)									
		6.0		6.5		7.0		7.5		8.0	
		Design Shear lb/ft	Design Shear Stiffness kips/in	Design Shear lb/ft	Design Shear Stiffness kips/in	Design Shear lb/ft	Design Shear Stiffness kips/in	Design Shear lb/ft	Design Shear Stiffness kips/in	Design Shear lb/ft	Design Shear Stiffness kips/in
30/4 End and Interior Supports	0	617	332.6	591	329.5	569	326.7	549	324.3	532	322.1
	1	657	349.1	628	345.1	603	341.6	581	338.4	562	335.6
	2	696	363.8	664	359.2	637	355.0	613	351.3	592	347.9
	3	736	377.0	701	371.8	671	367.2	644	363.0	622	359.2
	4	775	389.0	737	383.3	704	378.3	676	373.7	651	369.6
30/13 Panel Ends 30/4 Interior Supports	0	685	342.3	654	338.7	627	335.5	604	332.6	583	330.1
	1	724	357.8	690	353.4	661	349.5	635	346.0	613	342.8
	2	764	371.6	727	366.6	695	362.1	667	358.2	643	354.6
	3	804	384.1	763	378.6	729	373.7	699	369.3	672	365.3
	4	843	395.3	800	389.5	763	384.3	730	379.5	702	375.2
30/13 All Supports	0	753	351.5	716	347.3	685	343.7	658	340.5	634	337.6
	1	792	365.9	753	361.2	719	356.9	689	353.1	664	349.7
	2	832	378.9	789	373.6	753	368.9	721	364.7	693	360.9
	3	871	390.7	826	385.0	787	379.9	753	375.3	723	371.1
	4	911	401.3	862	395.3	821	389.9	784	385.1	753	380.6

**Notes:**

- Maximum span conditions are for diaphragm values only. In no case should the span exceed downward load carrying capabilities of the sheet.
- Insulperm is optional with these values. Insulperm when used is limited to 4-inch maximum thickness.
- Edge of diaphragm connections should not exceed the spacing, determined by the following formula:  

$$\text{Spacing (inches)} = 3690 Q_f / s$$

Where:  $Q_f$  = is weld strength (kips) from SDI Diaphragm Design Manual Section 4  
 $S$  = Design Shear (PLF)
- Design Shear Safety Factor = 3.25
- Boundary condition design should be calculated as indicated on the page titled Guide To Using The Insulcel and Zonocel Diaphragm Tables.

**Table 10**  
**Insulcel and Zonocel Concrete Diaphragm Values — Field of Diaphragm —**  
**Minimum 300 psi Concrete — 28-gauge Metal Decking —  $\frac{9}{16}$ -Inch Profile Depth**

Welding Pattern	Number Stitch Connectors	Spans (feet)									
		3		3.5		4		4.5		5	
		Design Shear lb/ft	Design Shear Stiffness kips/in	Design Shear lb/ft	Design Shear Stiffness kips/in	Design Shear lb/ft	Design Shear Stiffness kips/in	Design Shear lb/ft	Design Shear Stiffness kips/in	Design Shear lb/ft	Design Shear Stiffness kips/in
30/4 End and Interior Supports	0	523	429.4	497	424.6	478	420.7	463	417.4	450	414.5
	1	556	441.3	525	436.1	502	431.7	484	427.9	470	424.7
	2	589	450.2	554	445.0	527	440.4	506	436.5	490	433.0
	3	622	457.3	582	452.1	552	447.5	528	443.5	509	439.9
	4	655	463.0	610	457.9	576	453.4	550	449.4	529	445.8
30/13 Panel Ends 30/4 Interior Supports	0	639	449.4	597	444.1	565	439.5	540	435.6	520	432.1
	1	672	456.6	625	451.4	589	446.8	562	442.8	540	439.2
	2	705	462.5	653	457.3	614	452.8	584	448.8	559	445.2
	3	738	467.3	681	462.3	639	457.9	606	453.9	579	450.3
	4	771	471.3	709	466.5	663	462.2	627	458.3	599	454.7
30/13 All Supports	0	756	461.9	696	456.7	652	452.2	617	448.2	590	444.6
	1	788	466.8	724	461.8	677	457.4	639	453.4	609	449.8
	2	821	470.9	753	466.1	701	461.7	661	457.8	629	454.3
	3	854	474.4	781	469.7	726	465.5	683	461.7	649	458.2
	4	887	477.3	809	472.9	750	468.8	705	465.1	669	461.7

**Notes:**

1. Maximum span conditions are for diaphragm values only. In no case should the span exceed downward load carrying capabilities of the sheet.
2. Insulperm is optional with these values. Insulperm when used is limited to 4-inch maximum thickness.
3. Edge of diaphragm connections should not exceed the spacing, determined by the following formula:

$$\text{Spacing (inches)} = 3690 Q_f/s$$

Where:  $Q_f$  = is weld strength (kips) from SDI Diaphragm Design Manual Section 4

$S$  = Design Shear (PLF)

4. Design Shear Safety Factor = 3.25
5. Boundary condition design should be calculated as indicated on the page titled Guide To Using The Insulcel and Zonocel Diaphragm Tables.

**Table 11**  
**Insulcel and Zonocel Concrete Diaphragm Values — Field of Diaphragm —**  
**Minimum 300 psi Concrete — 26-gauge Metal Decking — <sup>15</sup>/<sub>16</sub> -Inch Profile Depth**

Welding Pattern	Number Stitch Connectors	Spans (feet)									
		4		4.5		5		5.5		6	
		Design Shear lb/ft	Design Shear Stiffness kips/in	Design Shear lb/ft	Design Shear Stiffness kips/in	Design Shear lb/ft	Design Shear Stiffness kips/in	Design Shear lb/ft	Design Shear Stiffness kips/in	Design Shear lb/ft	Design Shear Stiffness kips/in
30/4 End and Interior Supports	0	540	434.0	518	429.3	500	425.3	486	422.0	474	419.1
	1	570	448.3	544	442.9	524	438.2	507	434.2	493	430.7
	2	599	460.4	571	454.5	548	449.3	529	444.9	513	441.0
	3	629	470.6	597	464.4	571	459.0	550	454.3	533	450.0
	4	659	479.5	623	473.1	595	467.5	572	462.5	553	458.1
30/13 Panel Ends 30/4 Interior Supports	0	590	446.6	562	441.2	540	436.6	522	432.7	507	429.3
	1	619	458.9	588	453.0	564	448.0	544	443.6	527	439.7
	2	649	469.4	615	463.2	587	457.8	565	453.1	546	448.9
	3	679	478.4	641	472.0	611	466.5	587	461.5	566	457.1
	4	708	486.2	667	479.8	635	474.1	608	469.0	586	464.4
30/13 All Supports	0	640	457.4	606	451.6	580	446.6	558	442.2	540	438.4
	1	669	468.1	633	461.9	604	456.6	580	451.9	560	447.7
	2	699	477.3	659	470.9	627	465.4	601	460.5	580	456.1
	3	728	485.3	685	478.8	651	473.1	623	468.1	599	463.5
	4	758	492.2	712	485.8	675	480.0	644	474.9	619	470.2

**Notes:**

- Maximum span conditions are for diaphragm values only. In no case should the span exceed downward load carrying capabilities of the sheet.
- Insulperm is optional with these values. Insulperm when used is limited to 4-inch maximum thickness.
- Edge of diaphragm connections should not exceed the spacing, determined by the following formula:  

$$\text{Spacing (inches)} = 3690 Q_f / s$$

Where:  $Q_f$  = is weld strength (kips) from SDI Diaphragm Design Manual Section 4  
 $s$  = Design Shear (PLF)
- Design Shear Safety Factor = 3.25
- Boundary condition design should be calculated as indicated on the page titled Guide To Using The Insulcel and Zonocel Diaphragm Tables.

**Table 12**  
**Insulcel and Zonocel Concrete Diaphragm Values — Field of Diaphragm —**  
**Minimum 300 psi Concrete — 26-gauge Metal Decking — 1<sup>5</sup>/<sub>16</sub>-Inch Profile Depth**

Welding Pattern	Number Stitch Connectors	Spans (feet)									
		4		4.5		5		5.5		6	
		Design Shear lb/ft	Design Shear Stiffness kips/in	Design Shear lb/ft	Design Shear Stiffness kips/in	Design Shear lb/ft	Design Shear Stiffness kips/in	Design Shear lb/ft	Design Shear Stiffness kips/in	Design Shear lb/ft	Design Shear Stiffness kips/in
30/4 End and Interior Supports	0	518	422.5	498	418.8	483	415.7	470	413.1	459	410.8
	1	548	434.9	525	430.6	506	427.0	491	423.8	479	421.0
	2	577	445.0	551	440.4	530	436.4	513	432.9	498	429.8
	3	607	453.5	577	448.7	554	444.5	534	440.7	518	437.4
	4	636	460.6	604	455.7	577	451.4	556	447.5	538	444.1
30/7 Panel Ends 30/4 Interior Supports	0	553	430.0	530	425.9	511	422.5	495	419.5	483	416.9
	1	583	441.0	556	436.5	535	432.6	517	429.2	502	426.2
	2	613	450.1	582	445.4	558	441.2	539	437.6	522	434.3
	3	642	457.8	609	452.9	582	448.6	560	444.8	542	441.4
	4	672	464.3	635	459.4	606	455.0	582	451.1	562	447.6
30/7 All Supports	0	589	436.6	561	432.3	539	428.6	521	425.3	506	422.5
	1	618	446.5	588	441.8	563	437.8	543	434.2	526	431.0
	2	648	454.7	614	449.9	587	445.6	564	441.9	546	438.5
	3	678	461.7	640	456.8	610	452.4	586	448.5	565	445.0
	4	707	467.7	666	462.7	634	458.4	607	454.4	585	450.8

**Notes:**

- Maximum span conditions are for diaphragm values only. In no case should the span exceed downward load carrying capabilities of the sheet.
- Insulperm is optional with these values. Insulperm when used is limited to 4-inch maximum thickness.
- Edge of diaphragm connections should not exceed the spacing, determined by the following formula:

$$\text{Spacing (inches)} = 3690 Q_f / S$$

Where:  $Q_f$  = is weld strength (kips) from SDI Diaphragm Design Manual Section 4

$S$  = Design Shear (PLF)

- Design Shear Safety Factor = 3.25
- Boundary condition design should be calculated as indicated on the page titled Guide To Using The Insulcel and Zonocel Diaphragm Tables.

**Table 13**  
**Insulcel and Zonocel Concrete Diaphragm Values — Field of Diaphragm —**  
**Minimum 300 psi Concrete — 24-gauge Metal Decking — 1<sup>5</sup>/<sub>16</sub>-Inch Profile Depth**

Welding Pattern	Number Stitch Connectors	Spans (feet)									
		4.5		5		5.5		6		6.5	
		Design Shear lb/ft	Design Shear Stiffness kips/in	Design Shear lb/ft	Design Shear Stiffness kips/in	Design Shear lb/ft	Design Shear Stiffness kips/in	Design Shear lb/ft	Design Shear Stiffness kips/in	Design Shear lb/ft	Design Shear Stiffness kips/in
30/4 End and Interior Supports	0	581	426.7	557	422.9	538	419.6	521	416.8	507	414.4
	1	616	441.3	589	436.7	566	432.8	548	429.3	532	426.3
	2	652	453.7	621	448.6	595	444.1	574	440.2	556	436.7
	3	687	464.3	652	458.9	624	454.1	600	449.8	580	446.0
	4	722	473.5	684	467.8	653	462.8	627	458.3	605	454.3
30/13 Panel Ends 30/4 Interior Supports	0	629	435.5	600	431.2	577	427.5	557	424.3	541	421.5
	1	664	448.9	632	443.8	606	439.6	584	435.8	565	432.5
	2	700	460.1	664	454.7	634	450.1	610	445.9	589	442.3
	3	735	469.8	695	464.2	663	459.3	636	454.9	614	450.9
	4	770	478.3	727	472.6	692	467.4	663	462.9	638	458.7
30/13 All Supports	0	677	443.5	644	438.8	616	434.8	593	431.2	574	428.1
	1	712	455.6	675	450.4	645	445.9	620	441.9	598	438.3
	2	748	465.9	707	460.4	674	455.6	646	451.3	623	447.4
	3	783	474.9	739	469.2	702	464.2	672	459.6	647	455.6
	4	818	482.8	770	477.0	731	471.8	699	467.1	671	462.9

**Notes:**

- Maximum span conditions are for diaphragm values only. In no case should the span exceed downward load carrying capabilities of the sheet.
- Insulperm is optional with these values. Insulperm when used is limited to 4-inch maximum thickness.
- Edge of diaphragm connections should not exceed the spacing, determined by the following formula:

$$\text{Spacing (inches)} = 3690 Q_f / S$$

Where:  $Q_f$  = is weld strength (kips) from SDI Diaphragm Design Manual Section 4

$S$  = Design Shear (PLF)

- Design Shear Safety Factor = 3.25
- Boundary condition design should be calculated as indicated on the page titled Guide To Using The Insulcel and Zonocel Diaphragm Tables.

**Table 14**  
**Insulcel and Zonocel Concrete Diaphragm Values — Field of Diaphragm —**  
**Minimum 300 psi Concrete — 22-gauge Metal Decking — 1<sup>5</sup>/<sub>16</sub>-Inch Profile Depth**  
**and 1 1/2" B-Deck**

Welding Pattern	Number Stitch Connectors	Spans (feet)									
		5		5.5		6		6.5		7	
		Design Shear lb/ft	Design Shear Stiffness kips/in	Design Shear lb/ft	Design Shear Stiffness kips/in	Design Shear lb/ft	Design Shear Stiffness kips/in	Design Shear lb/ft	Design Shear Stiffness kips/in	Design Shear lb/ft	Design Shear Stiffness kips/in
30/4 End and Interior Supports	0	646	428.5	618	424.8	595	421.6	575	418.8	559	416.4
	1	685	444.9	654	440.3	628	436.2	606	432.7	587	429.6
	2	725	459.1	690	453.8	661	449.1	636	445.0	615	441.4
	3	764	471.5	726	465.7	694	460.6	667	456.1	643	452.1
	4	804	482.5	762	476.4	727	470.9	697	466.1	672	461.7
30/13 Panel Ends 30/4 Interior Supports	0	706	438.2	673	433.9	646	430.2	622	427.0	602	424.1
	1	746	453.3	709	448.2	678	443.8	653	439.9	630	436.5
	2	786	466.4	745	460.8	711	455.9	683	451.5	659	447.7
	3	825	478.0	781	472.0	744	466.7	713	462.0	687	457.7
	4	865	488.2	817	481.9	777	476.4	744	471.4	715	466.9
30/13 All Supports	0	767	447.1	729	442.4	696	438.2	669	434.6	645	431.4
	1	807	461.0	764	455.7	729	450.9	699	446.8	674	443.0
	2	846	473.2	800	467.4	762	462.2	730	457.7	702	453.6
	3	886	484.0	836	477.8	795	472.4	760	467.5	730	463.1
	4	926	493.6	872	487.2	828	481.5	791	476.4	759	471.8

**Notes:**

- Maximum span conditions are for diaphragm values only. In no case should the span exceed downward load carrying capabilities of the sheet.
- Insulperm is optional with these values. Insulperm when used is limited to 4-inch maximum thickness.
- Edge of diaphragm connections should not exceed the spacing, determined by the following formula:

$$\text{Spacing (inches)} = 3690 Q_f / S$$

Where:  $Q_f$  = is weld strength (kips) from SDI Diaphragm Design Manual Section 4

$S$  = Design Shear (PLF)

- Design Shear Safety Factor = 3.25
- Boundary condition design should be calculated as indicated on the page titled Guide To Using The Insulcel and Zonocel Diaphragm Tables.

**Table 15**  
**Insulcel and Zonocel Concrete Diaphragm Values — Field of Diaphragm —**  
**Minimum 300 psi Concrete — 20-gauge Metal Decking — 1<sup>5</sup>/<sub>16</sub>-Inch Profile Depth**

Welding Pattern	Number Stitch Connectors	Spans (feet)									
		6		6.5		7		7.5		8	
		Design Shear lb/ft	Design Shear Stiffness kips/in	Design Shear lb/ft	Design Shear Stiffness kips/in	Design Shear lb/ft	Design Shear Stiffness kips/in	Design Shear lb/ft	Design Shear Stiffness kips/in	Design Shear lb/ft	Design Shear Stiffness kips/in
30/4 End and Interior Supports	0	680	426.3	654	423.2	631	420.5	612	418	595	415.9
	1	719	442.9	690	438.9	665	435.3	644	432.2	625	429.4
	2	759	457.6	727	452.9	699	448.7	675	445	654	441.7
	3	798	470.8	763	465.6	733	460.9	707	456.7	684	453
	4	838	482.7	800	477.1	767	472	739	467.5	714	463.4
30/13 Panel Ends 30/4 Interior Supports	0	747	436.1	716	432.4	689	429.2	666	426.3	646	423.8
	1	787	451.5	753	447.1	723	443.2	698	439.7	676	436.6
	2	827	465.4	789	460.4	757	455.9	730	452.9	705	448.3
	3	866	477.8	826	472.3	791	467.4	761	463	735	459.1
	4	906	489	862	483.2	825	478	793	473.3	765	469
30/13 All Supports	0	815	445.2	779	441.1	747	437.4	720	434.2	697	431.3
	1	855	459.7	815	454.9	781	450.7	752	446.9	726	443.5
	2	894	472.7	852	467.4	815	462.7	784	458.4	756	454.6
	3	934	484.4	888	478.7	849	473.6	815	469	786	464.9
	4	974	495.1	925	489.1	883	483.7	847	478.8	815	474.4

**Notes:**

1. Maximum span conditions are for diaphragm values only. In no case should the span exceed downward load carrying capabilities of the sheet.
2. Insulperm is optional with these values. Insulperm when used is limited to 4-inch maximum thickness.
3. Edge of diaphragm connections should not exceed the spacing, determined by the following formula:

$$\text{Spacing (inches)} = 3690 Q_f / S$$

Where:  $Q_f$  = is weld strength (kips) from SDI Diaphragm Design Manual Section 4

$S$  = Design Shear (PLF)

4. Design Shear Safety Factor = 3.25
5. Boundary condition design should be calculated as indicated on the page titled Guide To Using The Insulcel and Zonocel Diaphragm Tables.



**Table 16**  
**ZIC Diaphragm Values — Field of Diaphragm**  
**Minimum 200 psi Concrete — 28-gauge Metal Decking —  $\frac{1}{16}$ -Inch Profile Depth**

Welding Pattern	Number Stitch Connectors	Spans (feet)									
		3.0		3.5		4.0		4.5		5.0	
		Design Shear lb/ft	Design Shear Stiffness kips/in	Design Shear lb/ft	Design Shear Stiffness kips/in	Design Shear lb/ft	Design Shear Stiffness kips/in	Design Shear lb/ft	Design Shear Stiffness kips/in	Design Shear lb/ft	Design Shear Stiffness kips/in
30/4 End and Interior Supports	0	461	335.7	435	330.9	415	326.9	400	323.6	388	320.8
	1	494	347.5	463	342.3	440	337.9	422	334.2	408	330.9
	2	526	356.5	491	351.2	464	346.7	444	342.7	427	339.2
	3	559	363.6	519	358.3	489	353.8	466	349.7	447	346.2
	4	592	369.3	547	364.2	514	359.7	487	355.6	467	352.0
30/13 Panel Ends  30/4 Interior Supports	0	577	355.6	534	350.3	502	345.8	477	341.9	457	338.4
	1	610	362.9	562	357.6	527	353.1	499	349.0	477	345.4
	2	642	368.7	590	363.6	551	359.1	521	355.0	497	351.4
	3	675	373.5	619	368.6	576	364.1	543	360.1	517	356.5
	4	708	377.5	647	372.8	601	368.4	565	364.5	536	361.0
30/13 All Supports	0	693	368.1	634	363.0	589	358.5	555	354.4	527	350.8
	1	726	373.0	662	368.1	614	363.6	577	359.6	547	356.0
	2	759	377.1	690	372.3	639	368.0	599	364.1	567	360.5
	3	791	380.6	718	376.0	663	371.8	620	367.9	586	364.4
	4	824	383.6	746	379.1	688	375.1	642	371.3	606	367.9

**Notes:**

1. Maximum span conditions are for diaphragm values only. In no case should the span exceed downward load carrying capabilities of the sheet.
2. Insulperm is optional with these values. Insulperm when used is limited to 4-inch maximum thickness.
3. Edge of diaphragm connections should not exceed the spacing, determined by the following formula:

$$\text{Spacing (inches)} = 3690 Q_f / S$$

Where:  $Q_f$  = is weld strength (kips) from SDI Diaphragm Design Manual Section 4

$S$  = Design Shear (PLF)

4. Design Shear Safety Factor = 3.25
5. Boundary condition design should be calculated as indicated on the page titled Guide To Using The Insulcel and Zonocel Diaphragm Tables.

**Table 17**  
**ZIC Diaphragm Values — Field of Diaphragm —**  
**Minimum 200 psi Concrete — 26-gauge Metal Decking — <sup>15</sup>/<sub>16</sub>-Inch Profile Depth**

Welding Pattern	Number Stitch Connectors	Spans (feet)									
		4.0		4.5		5.0		5.5		6.0	
		Design Shear lb/ft	Design Shear Stiffness kips/in	Design Shear lb/ft	Design Shear Stiffness kips/in	Design Shear lb/ft	Design Shear Stiffness kips/in	Design Shear lb/ft	Design Shear Stiffness kips/in	Design Shear lb/ft	Design Shear Stiffness kips/in
30/4 End and Interior Supports	0	477	340.2	455	335.5	438	331.6	423	328.2	411	325.3
	1	507	354.6	482	349.1	461	344.5	445	340.5	431	337.0
	2	537	366.6	508	360.7	485	355.6	466	351.1	451	347.2
	3	566	376.9	534	370.7	509	365.3	488	360.5	470	356.3
	4	596	385.7	561	379.4	532	373.8	509	368.8	490	364.4
30/9 Panel Ends  30/4 Interior Supports	0	527	352.8	500	347.5	477	342.9	459	339.0	444	335.5
	1	557	365.2	526	359.3	501	354.2	481	349.8	464	345.9
	2	586	375.6	552	369.5	525	364.1	502	359.3	484	355.1
	3	616	384.6	579	378.3	549	372.7	524	367.8	504	363.3
	4	646	392.5	605	386.0	572	380.3	546	375.3	523	370.7
30/9 All Supports	0	577	363.6	544	357.8	517	352.8	496	348.5	477	344.6
	1	607	374.3	570	368.2	541	362.8	517	358.2	497	354.0
	2	636	383.5	596	377.2	565	371.6	539	366.7	517	363.3
	3	666	391.5	623	385.1	588	379.4	560	374.3	537	369.8
	4	695	398.5	649	392.0	612	386.3	582	381.1	556	376.5

**Notes:**

- Maximum span conditions are for diaphragm values only. In no case should the span exceed downward load carrying capabilities of the sheet.
- Insulperm is optional with these values. Insulperm when used is limited to 4-inch maximum thickness.
- Edge of diaphragm connections should not exceed the spacing, determined by the following formula:  

$$\text{Spacing (inches)} = 3690 Q_f / S$$

Where:  $Q_f$  = is weld strength (kips) from SDI Diaphragm Design Manual Section 4  
 $S$  = Design Shear (PLF)
- Design Shear Safety Factor = 3.25
- Boundary condition design should be calculated as indicated on the page titled Guide To Using The Insulcel and Zonocel Diaphragm Tables.

**Table 18**  
**ZIC Diaphragm Values — Field of Diaphragm —**  
**Minimum 200 psi Concrete — 26-gauge Metal Decking — 1<sup>5</sup>/<sub>16</sub>-Inch Profile Depth**

Welding Pattern	Number of Stitch Connectors	Spans (feet)									
		4.0		4.5		5.0		5.5		6.0	
		Design Shear lb/ft	Design Shear Stiffness kips/in	Design Shear lb/ft	Design Shear Stiffness kips/in	Design Shear lb/ft	Design Shear Stiffness kips/in	Design Shear lb/ft	Design Shear Stiffness kips/in	Design Shear lb/ft	Design Shear Stiffness kips/in
30/4 End and Interior Supports	0	455	328.7	436	325.1	420	322.0	407	319.4	396	317.1
	1	485	341.1	462	336.9	444	333.2	429	330.0	416	327.3
	2	515	351.3	488	346.7	467	342.7	450	339.1	436	336.0
	3	544	359.7	515	354.9	491	350.7	472	347.0	456	343.6
	4	574	366.9	541	362.0	515	357.7	493	353.8	475	350.3
30/7 Panel Ends	0	491	336.2	467	332.2	448	328.7	433	325.8	420	323.2
	1	520	347.3	493	342.8	472	338.9	454	335.5	440	332.5
	2	550	356.4	520	351.6	496	347.5	476	343.8	459	340.6
30/4 Interior Supports	3	580	364.0	546	359.1	519	354.9	497	351.0	479	347.6
	4	609	370.5	572	365.6	543	361.3	519	357.3	499	353.8
30/7 All Supports	0	526	342.9	499	338.5	477	334.8	459	331.6	444	328.7
	1	556	352.7	525	348.1	500	344.0	480	340.5	463	337.3
	2	585	360.9	551	356.1	524	351.9	502	348.1	483	344.8
	3	615	367.9	578	363.0	548	358.7	523	354.8	503	351.3
	4	645	373.9	604	369.0	571	364.6	545	360.7	523	357.1

**Notes:**

- Maximum span conditions are for diaphragm values only. In no case should the span exceed downward load carrying capabilities of the sheet.
- Insulperm is optional with these values. Insulperm when used is limited to 4-inch maximum thickness.
- Edge of diaphragm connections should not exceed the spacing, determined by the following formula:

$$\text{Spacing (inches)} = 3690 Q_f / S$$

Where:  $Q_f$  = is weld strength (kips) from SDI Diaphragm Design Manual Section 4

$S$  = Design Shear (PLF)

- Design Shear Safety Factor = 3.25
- Boundary condition design should be calculated as indicated on the page titled Guide To Using The Insulcel and Zonocel Diaphragm Tables.

**Table 19**  
**ZIC Diaphragm Values — Field of Diaphragm —**  
**Minimum 200 psi Concrete — 24-gauge Metal Decking — 1<sup>5</sup>/<sub>16</sub>-Inch Profile Depth**

Welding Pattern	Number Stitch Connectors	Spans (feet)									
		4.5		5.0		5.5		6.0		6.5	
		Design Shear lb/ft	Design Shear Stiffness kips/in	Design Shear lb/ft	Design Shear Stiffness kips/in	Design Shear lb/ft	Design Shear Stiffness kips/in	Design Shear lb/ft	Design Shear Stiffness kips/in	Design Shear lb/ft	Design Shear Stiffness kips/in
30/4 End and Interior Supports	0	519	332.9	495	329.1	475	325.9	459	323.1	445	320.7
	1	554	347.6	526	343.0	504	339.0	485	335.6	469	332.5
	2	589	360.0	558	354.8	533	350.4	511	346.5	493	343.0
	3	624	370.6	590	365.1	561	360.3	538	356.1	518	352.3
	4	659	379.8	621	374.1	590	369.1	564	364.6	542	360.5
30/7 Panel Ends	0	567	341.8	538	337.5	514	333.8	495	330.6	478	327.8
	1	602	355.0	570	350.1	543	345.8	521	342.1	502	338.8
	2	637	366.3	601	361.0	572	356.3	547	352.2	527	348.5
30/4 Interior Supports	3	672	376.1	633	370.5	601	365.5	574	361.1	551	357.2
	4	707	384.6	664	378.8	629	373.7	600	369.1	575	365.0
30/7 All Supports	0	615	349.8	581	345.1	554	341.0	531	337.5	511	334.4
	1	650	361.8	613	356.6	582	352.1	557	348.1	536	344.6
	2	685	372.2	644	366.7	611	361.8	583	357.5	560	353.7
	3	720	381.2	676	375.5	640	370.4	610	365.9	584	361.8
	4	755	389.0	708	383.2	669	378.0	636	373.4	609	369.2

**Notes:**

1. Maximum span conditions are for diaphragm values only. In no case should the span exceed downward load carrying capabilities of the sheet.
2. Insulperm is optional with these values. Insulperm when used is limited to 4-inch maximum thickness.
3. Edge of diaphragm connections should not exceed the spacing, determined by the following formula:

$$\text{Spacing (inches)} = 3690 Q_f / S$$

Where:  $Q_f$  = is weld strength (kips) from SDI Diaphragm Design Manual Section 4

S = Design Shear (PLF)

4. Design Shear Safety Factor = 3.25
5. Boundary condition design should be calculated as indicated on the page titled Guide To Using The Insulcel and Zonocel Diaphragm Tables.

**Table 20**  
**ZIC Diaphragm Values — Field of Diaphragm —**  
**Minimum 200 psi Concrete — 22-gauge Metal Decking — 1<sup>5</sup>/<sub>16</sub>-Inch Profile Depth**  
**And 1 1/2-Inch B-Deck**

Welding Pattern	Number Stitch Connectors	Spans (feet)									
		5.0		5.5		6.0		6.5		7.0	
		Design Shear lb/ft	Design Shear Stiffness kips/in	Design Shear lb/ft	Design Shear Stiffness kips/in	Design Shear lb/ft	Design Shear Stiffness kips/in	Design Shear lb/ft	Design Shear Stiffness kips/in	Design Shear lb/ft	Design Shear Stiffness kips/in
30/4 End and Interior Supports	0	583	334.8	555	331.0	532	327.8	513	325.1	496	322.6
	1	622	351.2	591	346.5	565	342.5	543	338.9	524	335.8
	2	662	365.4	627	360.0	598	355.4	574	351.3	552	347.7
	3	702	377.8	663	372.0	631	366.9	604	362.4	581	358.3
	4	741	388.7	699	382.6	664	377.2	634	372.3	609	368.0
30/7 Panel Ends	0	644	344.5	611	340.2	583	336.5	559	333.2	539	330.4
	1	683	359.5	647	354.5	616	350.1	590	346.2	568	342.8
	2	723	372.7	683	367.1	649	362.2	620	357.8	596	353.9
30/4 Interior Supports	3	763	384.2	719	378.2	682	372.9	651	368.2	624	364.0
	4	802	394.4	754	388.2	715	382.6	681	377.6	652	373.1
30/7 All Supports	0	705	353.4	666	348.6	634	344.5	606	340.9	583	337.7
	1	744	367.3	702	361.9	667	357.2	637	353.0	611	349.3
	2	784	379.5	738	373.6	700	368.5	667	363.9	639	359.8
	3	823	390.2	774	384.1	773	378.6	698	373.7	668	369.3
	4	863	399.8	810	393.5	766	387.8	728	382.6	696	378.0

**Notes:**

1. Maximum span conditions are for diaphragm values only. In no case should the span exceed downward load carrying capabilities of the sheet.
2. Insulperm is optional with these values. Insulperm when used is limited to 4-inch maximum thickness.
3. Edge of diaphragm connections should not exceed the spacing, determined by the following formula:

$$\text{Spacing (inches)} = 3690 Q_f / S$$

Where:  $Q_f$  = is weld strength (kips) from SDI Diaphragm Design Manual Section 4

$S$  = Design Shear (PLF)

4. Design Shear Safety Factor = 3.25
5. Boundary condition design should be calculated as indicated on the page titled Guide To Using The Insulcel and Zonocel Diaphragm Tables.

**Table 21**  
**ZIC Diaphragm Values — Field of Diaphragm —**  
**Minimum 200 psi Concrete — 20-gauge Metal Decking — 1<sup>5</sup>/<sub>16</sub>-Inch Profile Depth**

Welding Pattern	Number of Stitch Connectors	Spans (feet)									
		6.0		6.5		7.0		7.5		8.0	
		Design Shear lb/ft	Design Shear Stiffness kips/in	Design Shear lb/ft	Design Shear Stiffness kips/in	Design Shear lb/ft	Design Shear Stiffness kips/in	Design Shear lb/ft	Design Shear Stiffness kips/in	Design Shear lb/ft	Design Shear Stiffness kips/in
30/4 End and Interior Supports	0	617	332.6	591	329.5	569	326.7	549	324.3	532	322.1
	1	657	349.1	628	345.1	603	341.6	581	338.4	562	335.6
	2	696	363.8	664	359.2	637	355.0	613	351.3	592	347.9
	3	736	377.0	701	371.8	671	367.2	644	363.0	622	359.2
	4	775	389.0	737	383.3	704	378.3	676	373.7	651	369.6
30/7 Panel Ends	0	685	342.3	654	338.7	627	335.5	604	332.6	583	330.1
	1	724	357.8	690	353.4	661	349.5	635	346.0	613	342.8
	2	764	371.6	727	366.6	695	362.1	667	358.2	643	354.6
30/4 Interior Supports	3	804	384.1	763	378.6	729	373.7	699	369.3	672	365.3
	4	843	395.3	800	389.5	763	384.3	730	379.5	702	375.2
30/7 All Supports	0	753	351.5	716	347.3	685	343.7	658	340.5	634	337.6
	1	792	365.9	753	361.2	719	356.9	689	353.1	664	349.7
	2	832	378.9	789	373.6	753	368.9	721	364.7	693	360.9
	3	871	390.7	826	385.0	787	379.9	753	375.3	723	371.1
	4	911	401.3	862	395.3	821	389.9	784	385.1	753	380.6

**Notes:**

1. Maximum span conditions are for diaphragm values only. In no case should the span exceed downward load carrying capabilities of the sheet.
2. Insulperm is optional with these values. Insulperm when used is limited to 4-inch maximum thickness.
3. Edge of diaphragm connections should not exceed the spacing, determined by the following formula:

$$\text{Spacing (inches)} = 3690 Q_f / S$$

Where:  $Q_f$  = is weld strength (kips) from SDI Diaphragm Design Manual Section 4

$S$  = Design Shear (PLF)

4. Design Shear Safety Factor = 3.25
5. Boundary condition design should be calculated as indicated on the page titled Guide To Using The Insulcel and Zonocel Diaphragm Tables.